

Input voltage	Output voltage	Output current	Output power	Efficiency	Size
18-90V DC	12V DC	5 Amps	60 Watts	90.6%	64*57*22mm

The RW-1136-72-12V-60W is a Non-isolated DC-DC converter that uses a synchronous rectification technology, and features high efficiency and power density. It has the dimensions of 64*57*22mm (2.52 in. x 2.24 in. x 0.87 in) and provides the rated output voltage of 12V and the maximum output current of 5A.

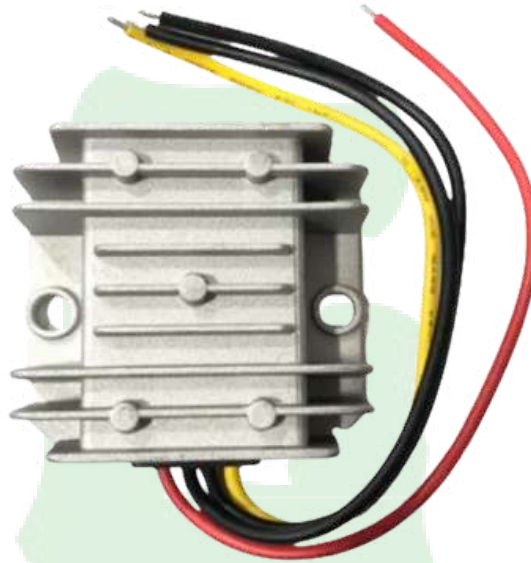

Features

- Design meeting RoHS / CE
- High efficiency: 90.6% (@ 72Vin, 25°C)
- Non-isolated between input and output
- Support -40 °C environment
- 100% full load burn-in test
- Short circuit, Over load, Low-voltage protections
- Waterproof level IP67
- Small size, high reliability
- 3 Months warranty

Applications

- Industrial
- Alternative Energy
- Golf Cart
- Cars & Forklift
- Electromotor
- Telecommunications
- Boat & Yacht
- Medical
- LED Marketplaces and so on.

Model naming method
RW-1136-72-12V-60W

RW-1136 SKU NAME
72V-Input Voltage
12V-Output Voltage
60W-Output Power

Electrical Specifications

Conditions: TA = 25 °C (77°F), Airflow = 1 m/s (200LFM), Vin =72V, Vout =12V, unless otherwise specified

Parameter	Min.	Typ	Max.	Units	Remarks
Absolute maximum ratings					
Operating ambient temperature	-40	-	+50	°C	
Shell ambient temperature	-40	-	80	°C	
Storage temperature	-55	-	100	°C	
Operating humidity	5	-	95	%	Non-condensing
Atmospheric pressure	62	-	106	Kpa	
Altitude	-	-	4000	m	
Cooling way	-	-	-		Natural cooling

Input characteristics

Input voltage	18	72	90	V	-
Max. input voltage	-	-	90	V	Continuous
Undervoltage shutdown	14.7	15.1	15.4	V	Automatic recovery
Undervoltage recovery	16.5	16.7	16.9	V	Automatic recovery
Max. input current	-	-	3.6	A	Vin =18V; Iout =5A
No load current	-	35	50	mA	Vin =72V

Positive electrode cable	18	-	-	AWG	If the wire length is greater than 50cm, it is recommended to use a thicker wire diameter.
Negative electrode cable	18	-	-	AWG	
Enable PIN cable	-	NA	-	AWG	If the unit with this function
Fuse	-	20	-	A	Input positive has built-in fuse

Output characteristics

Efficiency	-	90.6	-	%	Vin =72V; Iout =5A
Output voltage	11.9	12	12.3	V	Vin =72V; Iout =5A
Regulator accuracy	-	±2	-	%	
Voltage regulation	-	±2	-	%	
Load Regulation	-	±2	-	%	
Oversvoltage protection	-	NA	-	V	
Output current	0	-	5	A	Vin=18-90V
Overcurrent protection	-	11	12	A	Vin=72V
External capacitance	-	NA	-	μF	DON'T NEED
Output ripple and noise	-	96	200	mVp-p	Vin =18-90V; Iout=5A Oscilloscope bandwidth: 20 MHz;
Output voltage rise time	-	75	100	mS	
Boot delay time	-	102	120	mS	
Out voltage overshoot	-	1	2	%	Vin =72V
Over temperature protection	-		100	°C	Shell test
Short circuit protection	-	YES	-	-	Long-term (4 hours) short circuit is not damaged, Hiccup mode
Positive electrode cable	18	-	-	AWG	If the wire length is greater than 50cm, it is recommended to use a thicker wire diameter.
Negative electrode cable	18	-	-	AWG	

Feature Description

Remote On/Off (EN) (Optional)

Logic Enable	Low level (0 - 18Vdc)	High level (28-60Vdc)	Left open
Positive logic	Off	On	Off

Input Undervoltage Protection

The converter will shut down after the input voltage drops below the under-voltage protection threshold for shutdown. The converter will start to work again after the input voltage reaches the input under voltage protection threshold for startup. For the Hysteresis, see

Various circuits for driving the EN

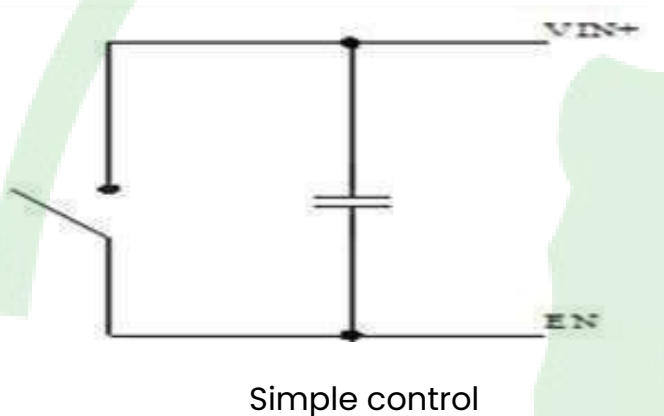

Output Overcurrent Protection

The converter equipped with current limiting circuitry can provide protection from an output overload or short circuit condition. If the output current exceeds the output overcurrent protection set point, the converter enters hiccup mode. When the fault condition is removed, the converter will automatically restart.

Wiring Instructions

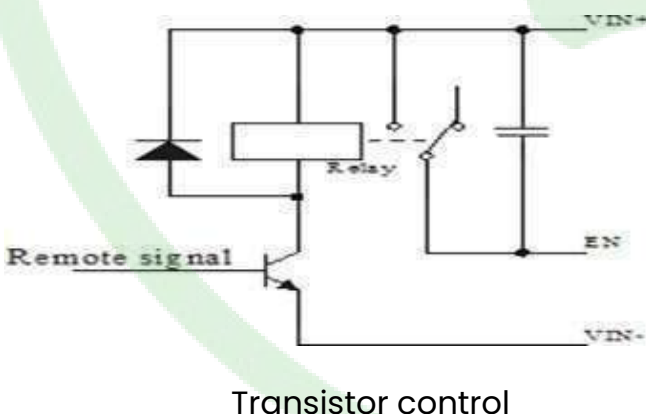

The input and output of this product is terminals. The user should ensure that the input and output wires and terminals are connected reliably, and pay attention to the wire diameter to meet the requirements of the power supply current. If the cable to be used is long, it needs Considering the voltage drop of the wire, if the voltage drop is too large, the voltage output at the load end may not meet the load demand. In this case, consider using a thicker wire diameter or reducing the length of the wire. Generally, if long wiring is required. Long line should be used on the side where the current is relatively small. For example, this product is a step-down product, so long lines should be used on the input side.

DIAGRAM WIRING

INPUT+ TO BATTERY+

INPUT- TO BATTERY-

OUTPUT+ TO LOAD+

OUTPUT- TO LOAD-

Notes: Never reverse the input polarity, or it burns the converter.

REVISION HISTORY

rev.	description	date
1.0	initial release	April 2022
2.0	revision	Nov 2024

Safety and EMC features

Anti-electric Strength	Input to Output	-	V	Leakage current $\leq 3.5\text{mA}$, 1min, no breakdown, no arcing
	Input to Shell	≥ 500	V	
	Output to Shell	≥ 500	V	
Insulation resistance	Input to Output	≥ 10	M Ω	Test voltage = 500V
	Input to Shell			
	Output to Shell			

Other characteristics

Weight	≤ 120	g	
Package	White box		
MTBF	$\geq 200,000$	H	Vin= 72V; Iout= 5A
Switching frequency	140 \pm 10	KHz	

Characteristic Curves

Conditions: TA = 25°C (77°F), Vin = 72V, Vout = 12V , unless otherwise specified.

Figure 1, Efficiency

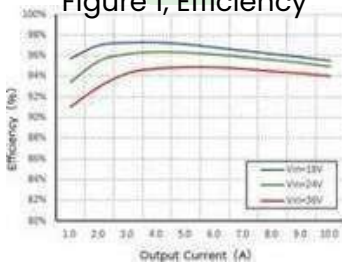

Figure 3, Input V-I, Iout=5A

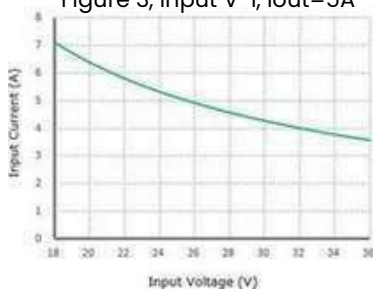
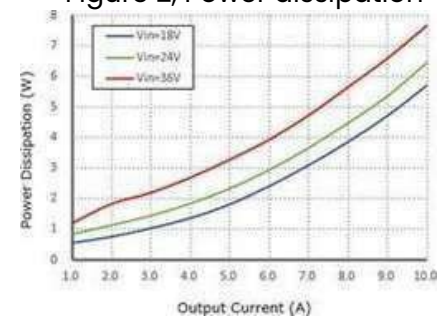

Figure 2, Power dissipation



Typical Waveforms

Conditions: $T_A = 25^\circ\text{C}$ (77°F), $V_{in} = 72\text{V}$, unless otherwise specified..

Figure 4, 25% - 50% load dynamic



Figure 5, 50% - 75% load dynamic



Figure 6, Output voltage established (I_{out} = 5A)

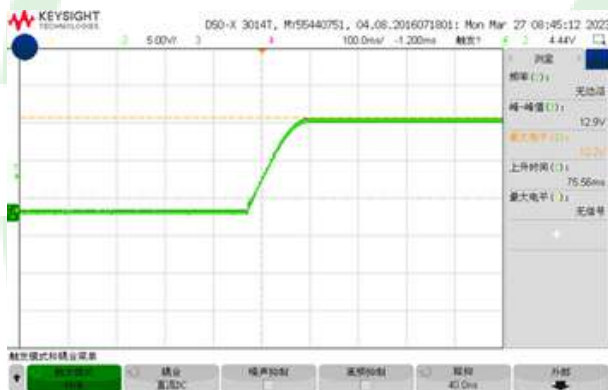

Figure 7, Output ripple & noise (I_{out} = 5A)

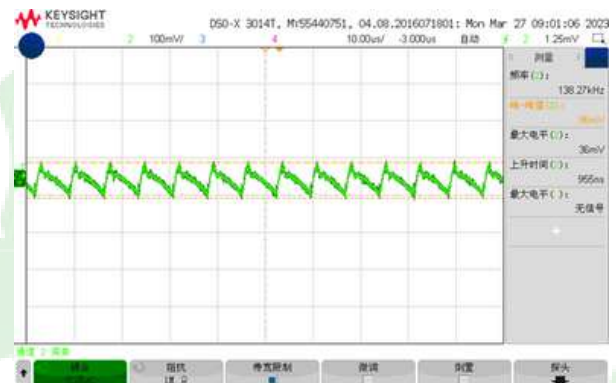

Figure 8, Boot delay time

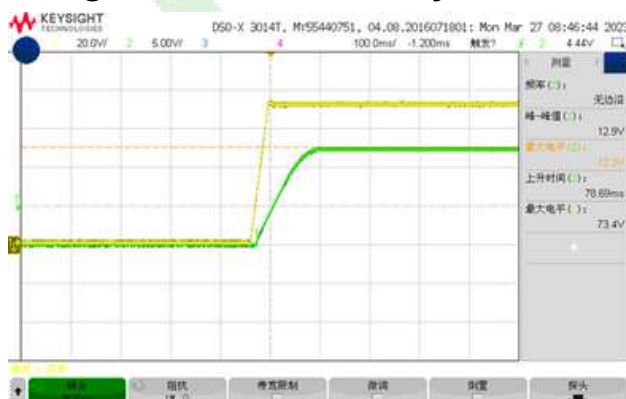
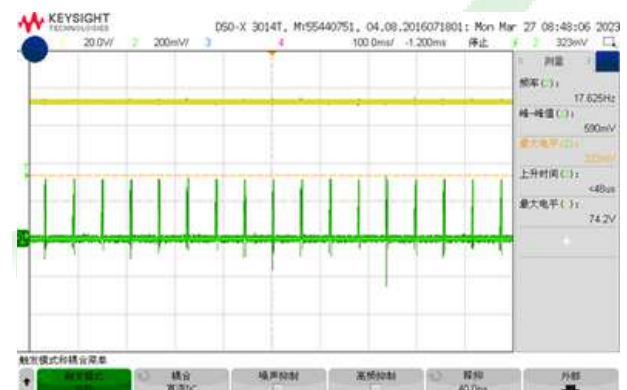
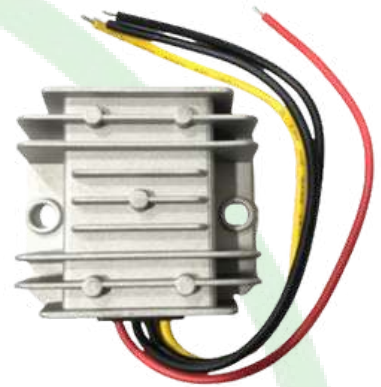

Figure 9, Short circuit & Output voltage



Thermal Consideration

Sufficient airflow should be provided to help ensure reliable operating of the RW-1136-72-12V-60W. Therefore, thermal components are mounted on the top surface of the RW-1136-72-12V-60W to dissipate heat to the surrounding environment by conduction, convection, and radiation. Proper airflow can be verified by measuring the temperature at the middle of the base plate.



Shell installation diagram

Thickness : 22mm

Center distance : 54mm

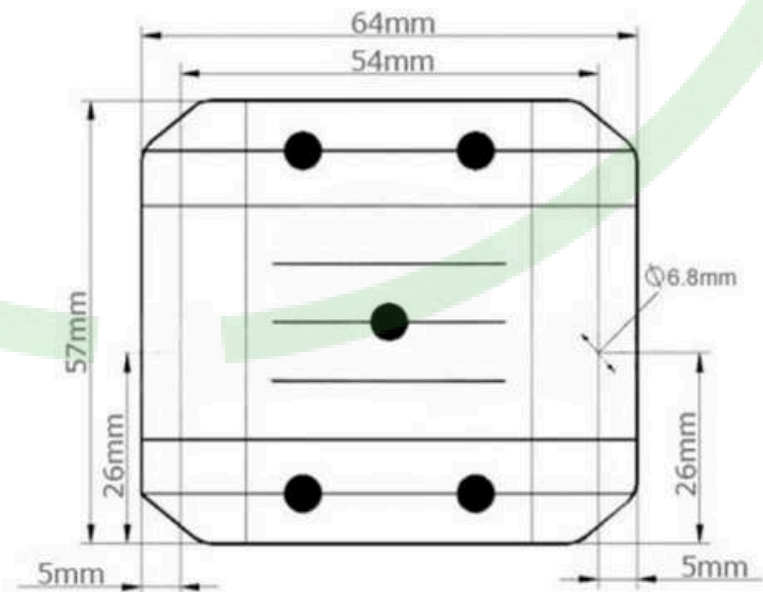

NEWTECH ENTERPRISES Ltd reserves the ©copyright and right of final interpretation.