

Input voltage	Output voltage	Output current	Output power	Efficiency	Size
10-24V DC	48V DC	2 Amps	96 Watts	94%	64*57*22mm

The RW-931-12-48-96W is a Non-isolated DC-DC converter that uses a synchronous rectification technology, and features high efficiency and power density. It has the dimensions of 64*57*22mm (2.52 in. x 2.24 in. x 0.86 in) and provides the rated output voltage of 48V and the maximum output current of 2A.

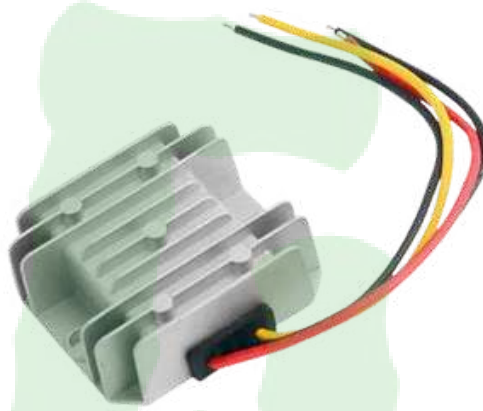

Features

- Design meeting RoHS / CE
- High efficiency: 90.8% (@ 24Vin, 25°C)
- Import capacitors, high reliability
- Output transient absorption protection
- Support -40 °C environment
- 100% full load burn-in test
- 3 month warranty
- Remote ON/OFF control (optional)
- Waterproof level IP68

Applications

- Industrial
- Alternative Energy
- Golf Cart
- Forklift
- Electromotor
- Telecommunications
- Boat & Yacht
- Medical
- LED Marketplaces and so on.

Model naming method
RW-931-12-48-96W

RW-931: SKU NAME
12V Input voltage
48V : Output voltage
96W: Output Power

Electrical Specifications

Conditions: TA = 25 °C (77°F), Airflow = 1 m/s (200LFM), Vin =12V, Vout =48V, unless otherwise specified.

Parameter	Min.	Typ	Max.	Units	Remarks
Absolute maximum ratings					
Operating ambient temperature	-40	-	+50	°C	
Shell ambient temperature	-40	-	80	°C	
Storage temperature	-55	-	100	°C	
Operating humidity	5	-	95	%	Non-condensing
Atmospheric pressure	62	-	106	Kpa	
Altitude	-	-	4000	m	
Cooling way	-	-	-		Natural cooling

Input characteristics

Input voltage	10	12	24	V	-
Max. input voltage	-	-	36	V	Continuous
Undervoltage shutdown	7.6	8.0	8.5	V	Automatic recovery
Undervoltage recovery	9.0	9.3	9.5	V	Automatic recovery
Max. input current	-	-	11	A	Vin =10V; Iout =2A
No load current	-	40	60	mA	Vin =12V

Positive electrode cable	16	-	-	AWG	If the wire length is greater than 50cm, it is recommended to use a thicker wire diameter.
Negative electrode cable	16	-	-	AWG	
Enable PIN cable	-	NA	-	AWG	If the product has this feature
Fuse	-	20	-	A	Input positive has built-in fuse

Output characteristics

Efficiency	-	94	-	%	Vin =12V; Iout =2A
Output voltage	47.7	48.0	48.4	V	Vin =12V; Iout =2A
Regulator accuracy	-	±5	-	%	
Voltage regulation	-	±3	-	%	
Load Regulation	-	±3	-	%	
Overvoltage protection	-	NA	-	V	
Output current	0	-	2	A	
Overcurrent protection	2.6	3.0	3.4	A	Vin=12V
External capacitance	0	NA	-	μF	Don't need
Output ripple and noise	-	440	500	mVp-p	Vin =10-23V; Iout=2A, Oscilloscope bandwidth: 20 MHz
Output voltage rise time	-	7	12	mS	
Boot delay time	-	15	20	mS	
Out voltage overshoot	-		5	%	Vin =12V, 50%-75% Load step
Over temperature protection	-	-	85	°C	Shell test
Short circuit protection	-	NA	-		Output can't shorted for boost converters
Positive electrode cable	18	-	-	AWG	If the wire length is greater than 50cm, it is recommended to use a thicker wire diameter.
Negative electrode cable	18	-	-	AWG	

Feature Description

Remote On/Off (EN) (Optional)

Logic Enable	Low level (0 - 18Vdc)	High level (18-36Vdc)	Left open
Positive logic	Off	On	Off

Input Undervoltage Protection

The converter will shut down after the input voltage drops below the under-voltage protection threshold for shutdown. The converter will start to work again after the input voltage reaches the input under voltage protection threshold for startup. For the Hysteresis, see

Various circuits for driving the EN

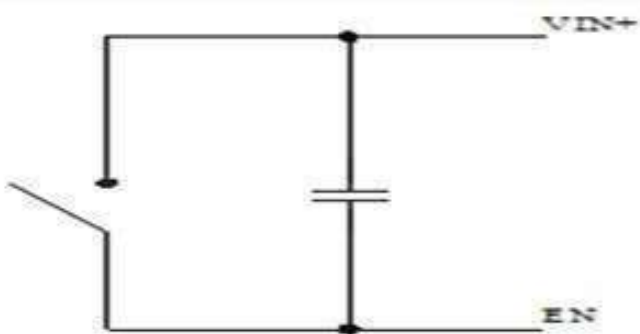

Simple control

Output Overcurrent Protection

The converter equipped with current limiting circuitry can provide protection from an output overload or short circuit condition. If the output current exceeds the output overcurrent protection set point, the converter enters hiccup mode. When the fault condition is removed, the converter will automatically restart.

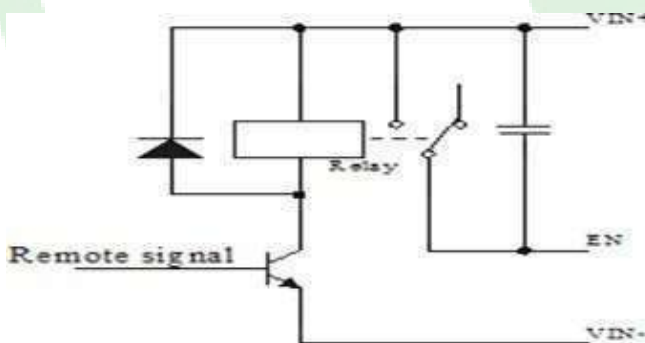

Transistor control

Wiring Instructions

The input and output of this product is terminals. The user should ensure that the input and output wires and terminals are connected reliably, and pay attention to the wire diameter to meet the requirements of the power supply current. If the cable to be used is long, it needs considering the voltage drop of the wire, if the voltage drop is too large, the voltage output at the load end may not meet the load demand. In this case, consider using a thicker wire diameter or reducing the length of the wire. Generally, if long wiring is required, long line should be used on the side where the current is relatively small. For example, this product is a step-down product, so long lines should be used on the input side.

DIAGRAM WIRING

INPUT+ TO BATTERY+

INPUT- TO BATTERY-

OUTPUT+ TO LOAD+

OUTPUT- TO LOAD-

Notes: Never reverse the input polarity, or it burns the converter.

REVISION HISTORY

rev.	description	date
1.0	initial release	April 2022
2.0	revision	Nov 2024

Safety and EMC features

Anti-electric Strength	Input to Output		V	Leakage current $\leq 3.5\text{mA}$, 1min, no breakdown, no arcing
	Input to Shell	≥ 500	V	
	Output to Shell	≥ 500	V	
Insulation resistance	Input to Output	≥ 50	M Ω	Test voltage = 500V
	Input to Shell			
	Output to Shell			

Other characteristics

Weight	≤ 120	g	
Package	White box		
MTBF	$\geq 200,000$	H	Vin= 12V; Iout= 2A
Switching frequency	130 \pm 10	KHz	

Characteristic Curves

Conditions: TA = 25°C (77°F), Vin = 12 V, Vout = 48 V, unless otherwise specified.

Figure 1, Efficiency

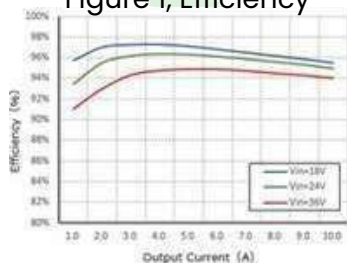

Figure 3, Input V-I, Iout=2A

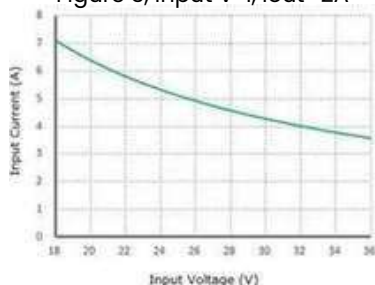
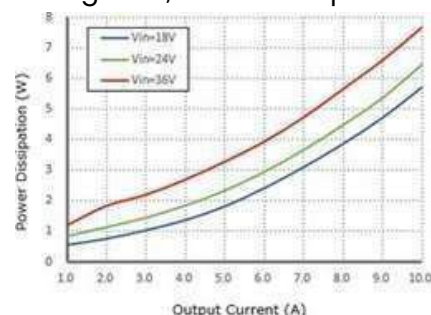

Figure 2, Power dissipation



Typical Waveforms

Conditions: $T_A = 25^{\circ}\text{C}$ (77°F), $V_{in} = 24\text{V}$, unless otherwise specified.

Figure 4, 25% - 50% load dynamic

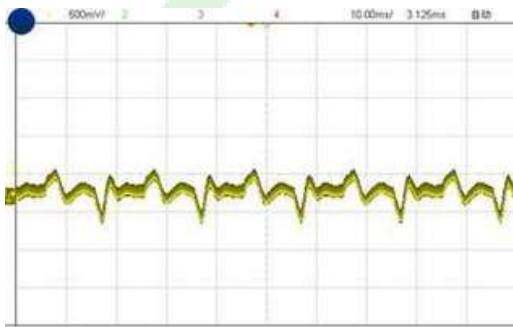

Figure 5, 50% - 75% load dynamic

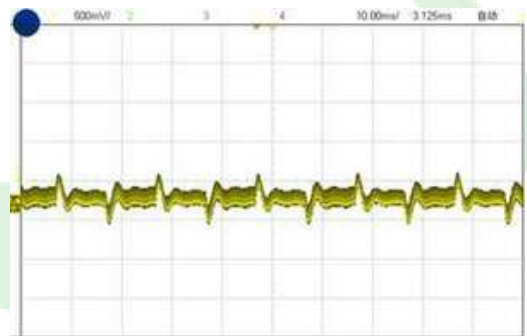
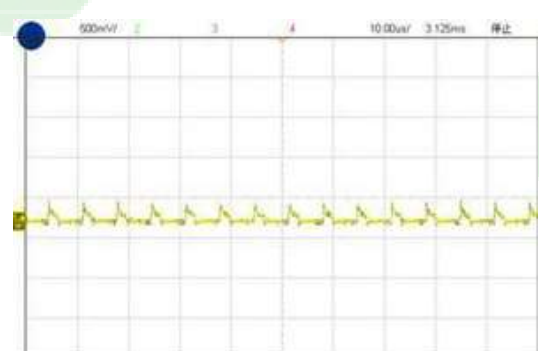

Figure 6, Output voltage established ($I_{out} = 2\text{A}$)



Figure 7, Output ripple & noise ($I_{out} = 2\text{A}$)



Thermal Consideration

Sufficient airflow should be provided to help ensure reliable operating of the RW-931-12-48-96W. Therefore, thermal components are mounted on the top surface of the RW-931-12-48-96W to dissipate heat to the surrounding environment by conduction, convection, and radiation. Proper airflow can be verified by measuring the temperature at the middle of the base plate.



Shell installation diagram
Thickness : 27mm
Center distance : 54mm

