

Input voltage	Output voltage	Output current	Output power	Efficiency	Size
18-36V	12V	30 Amps	360 Watts	96%	74*74*32mm

The RW-984-24-12V-360W is a Non-isolated DC-DC converter that uses a synchronous rectification technology, and features high efficiency and power density. It has the dimensions of 74\*74\*32mm ((2.91 in. x 2.91 in. x 1.26 in) and provides the rated output voltage of 12 V and the maximum output current of 30A.

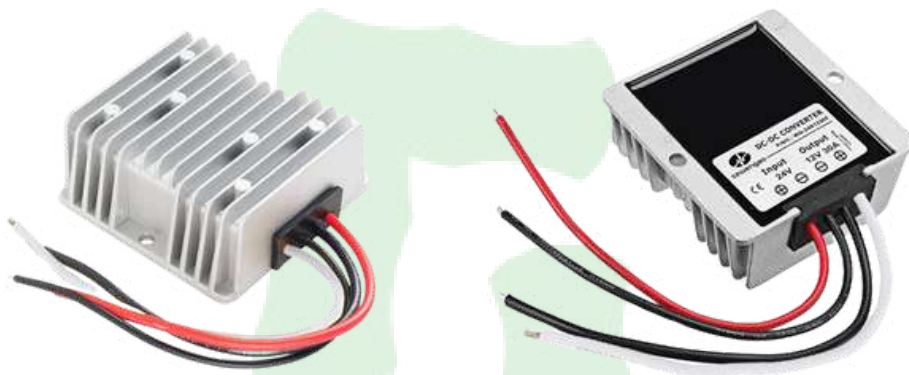

### Features

- Design meeting RoHS / CE
- High efficiency: 90.8% (@ 24Vin, 25°C)
- Import capacitors, high reliability
- Output transient absorption protection
- Support -40 °C environment
- 100% full load burn-in test
- 3 month warranty
- Remote ON/OFF control (optional)
- Waterproof level IP68

### Applications

- Industrial
- Alternative Energy
- Golf Cart
- Forklift
- Electromotor
- Telecommunications
- Boat & Yacht
- Medical
- LED Marketplaces and so on.

Model naming method  
RW-984-24-12V-360W

RW-984: SKU NAME  
24V Input voltage  
12V : Output voltage  
360W: Output Power

## Electrical Specifications

Conditions: TA = 25 °C (77°F), Airflow = 1 m/s (200LFM), Vin =24V, Vout =12V, unless otherwise specified

Parameter	Min.	Typ	Max.	Units	Remarks
Absolute maximum ratings					
Operating ambient temperature	-40	-	+50	°C	
Shell ambient temperature	-40	-	80	°C	
Storage temperature	-55	-	100	°C	
Operating humidity	5	-	95	%	Non-condensing
Atmospheric pressure	62	-	106	Kpa	
Altitude	-	-	4000	m	
Cooling way	-	-	-		Natural cooling

## Input characteristics

Input voltage	18	24	36	V	-
Max. input voltage	-	-	36	V	Continuous
Undervoltage shutdown	16.9	17.1	17.3	V	Automatic recovery
Undervoltage recovery	17.6	17.7	17.8	V	Automatic recovery
Max. input current	-	-	22	A	Vin =17.4V; Iout =30A
No load current	-	51	54	mA	Vin = 24V

Positive electrode cable	14	-	-	AWG	If the wire length is greater than 50cm, it is recommended to use a thicker wire diameter.
Negative electrode cable	14	-	-	AWG	
Enable PIN cable	-	-	-	AWG	If the product has this feature
Fuse	-	30	-	A	Input positive has built-in fuse

## Output characteristics

Efficiency	-	96.0	-	%	Vin =24V; Iout =30A
Output voltage	11.9	12.0	12.3	V	Vin =24V; Iout =30A
Regulator accuracy	-	±1	-	%	
Voltage regulation	-	±1	-	%	
Load Regulation	-	±1	-	%	
Overshoot protection	-	--	-	V	
Output current	0	-	30	A	
Overcurrent protection	37.7	38	38.3	A	Vin=24V
External capacitance	0	3000	4000	μF	
Output ripple and noise	-	70	100	mVp-p	Vin =18-36V; Iout=30A, Oscilloscope bandwidth: 20 MHz
Output voltage rise time	-	69	73	mS	
Boot delay time	-	96	100	mS	
Out voltage overshoot	-	1	2	%	Vin =24V, 50%-75% Load step
Over temperature protection	-	-	100	°C	Shell temperature, @ 100°C Restore working
Short circuit protection	-	-	-	-	Long-term (4 hours) short circuit is not damaged, Hiccup mode
Positive electrode cable	12	-	-	AWG	If the wire length is greater than 50cm, it is recommended to use a thicker wire diameter.
Negative electrode cable	12	-	-	AWG	

## Feature Description

### Remote On/Off (EN) (Optional)

Logic Enable	Low level (0 - 18Vdc)	High level (18-36Vdc)	Left open
Positive logic	Off	On	Off

### Input Undervoltage Protection

The converter will shut down after the input voltage drops below the under-voltage protection threshold for shutdown. The converter will start to work again after the input voltage reaches the input under voltage protection threshold for startup. For the Hysteresis, see

### Various circuits for driving the EN

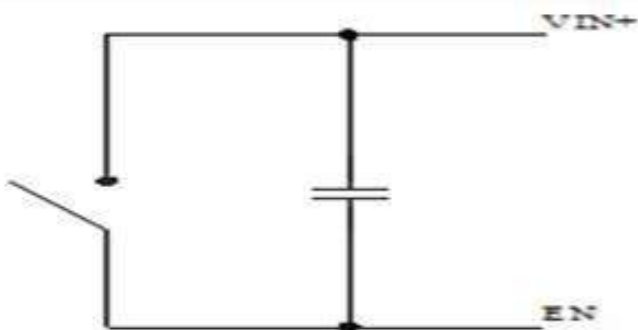

Simple control

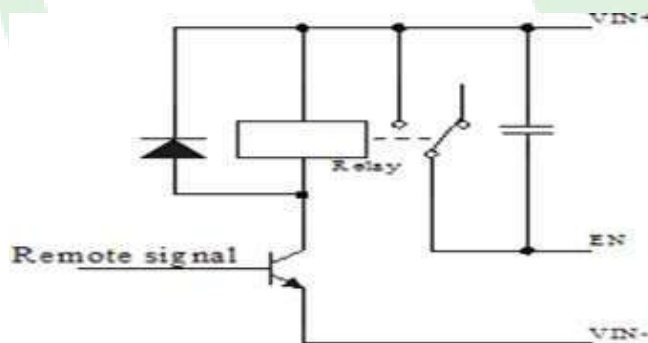

Transistor control

### Output Overcurrent Protection

The converter equipped with current limiting circuitry can provide protection from an output overload or short circuit condition. If the output current exceeds the output overcurrent protection set point, the converter enters hiccup mode. When the fault condition is removed, the converter will automatically restart.

### Wiring Instructions

The input and output of this product is terminals. The user should ensure that the input and output wires and terminals are connected reliably, and pay attention to the wire diameter to meet the requirements of the power supply current. If the cable to be used is long, it needs considering the voltage drop of the wire, if the voltage drop is too large, the voltage output at the load end may not meet the load demand. In this case, consider using a thicker wire diameter or reducing the length of the wire. Generally, if long wiring is required. Long line should be used on the side where the current is relatively small. For example, this product is a step-down product, so long lines should be used on the input side.

**DIAGRAM WIRING**

INPUT+ TO BATTERY+

INPUT- TO BATTERY-

OUTPUT+ TO LOAD+

OUTPUT- TO LOAD-

Notes: Never reverse the input polarity, or it burns the converter.

**REVISION HISTORY**

rev.	description	date
1.0	initial release	April 2022
2.0	revision	Nov 2024

### Typical Waveforms

Conditions: TA = 25°C (77°F), Vin = 24V, unless otherwise specified.

Figure 4, 25% - 50% load dynamic

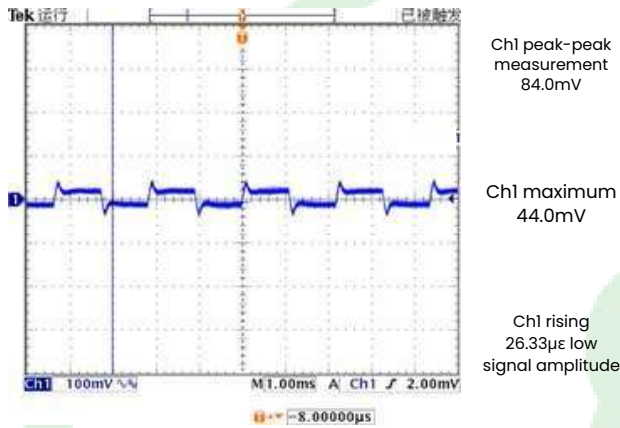

Figure 5, 50% - 75% load dynamic

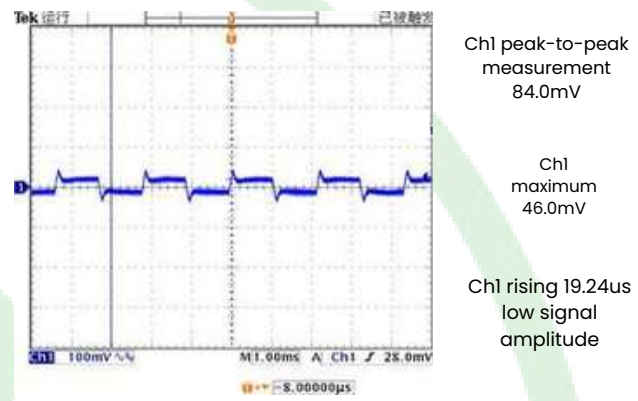

Figure 6, Output voltage established (Iout = 30A)

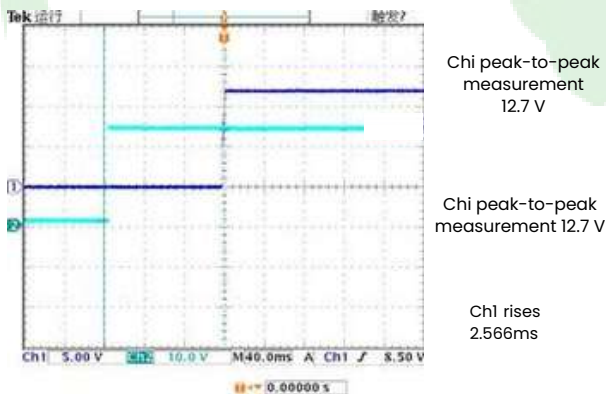
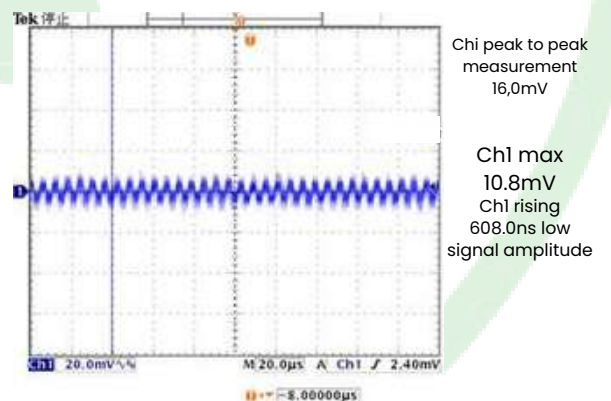

Figure 7, Output ripple & noise (Iout = 30A)



## Safety and EMC features

Anti-electric Strength	Input to Output		V	Leakage current $\leq 3.5\text{mA}$ , 1min, no breakdown, no arcing
	Input to Shell	$\geq 500$	V	
	Output to Shell	$\geq 500$	V	
Insulation resistance	Input to Output	$\geq 50$	$M\Omega$	Test voltage = 500V
	Input to Shell			
	Output to Shell			

## Other characteristics

Weight	$\leq 70$	g	
Package	White box		
MTBF	$\geq 200,000$	H	$V_{in} = 24\text{V}; I_{out} = 30\text{A}$
Switching frequency	$135 \pm 10$	KHz	

## Characteristic Curves

Conditions:  $T_A = 25^\circ\text{C}$  (77°F),  $V_{in} = 24\text{V}$ ,  $V_{out} = 12\text{V}$ , unless otherwise specified

Figure 1, Efficiency

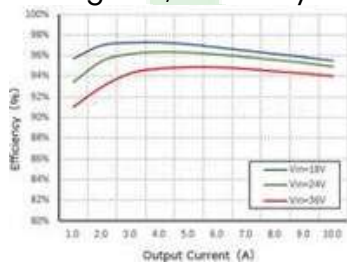

Figure 3, Input V-I,  $I_{out}=30\text{A}$

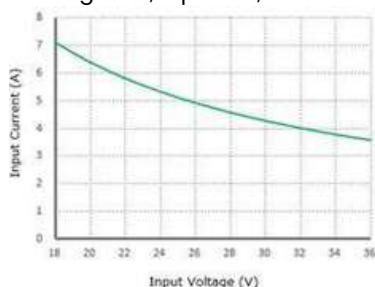
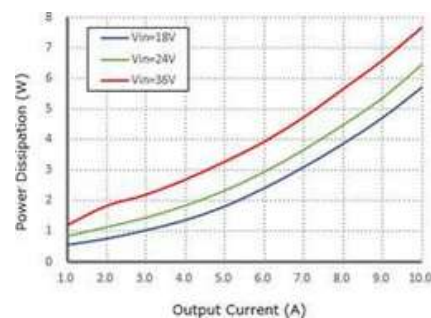

Figure 2, Power dissipation





## SAFETY AND COMPLIANCE

Parameter	Test conditions or description				
safety approvals	EN 61000-6-3:2007/A1:2011/AC:2012 EN 55014-1:2006/A2:2011 EN 60950-1:2006/AC:2011				
enclosures	IP68				

## ENVIRONMENTAL

Parameter	Test conditions or description	Min	Typ	Max	Units
case operating temperature		40	25	85	°C
ambient temperature		-20		85	°C
storage temperature		40		95	°C
humidity				95	%

### Thermal Consideration

Sufficient airflow should be provided to help ensure reliable operating of the RW-984-24-12V-360W. Therefore, thermal components are mounted on the top surface of the RW-984-24-12V-360W

to dissipate heat to the surrounding environment by conduction, convection, and radiation. Proper airflow can be verified by measuring the temperature at the middle of the base plate.

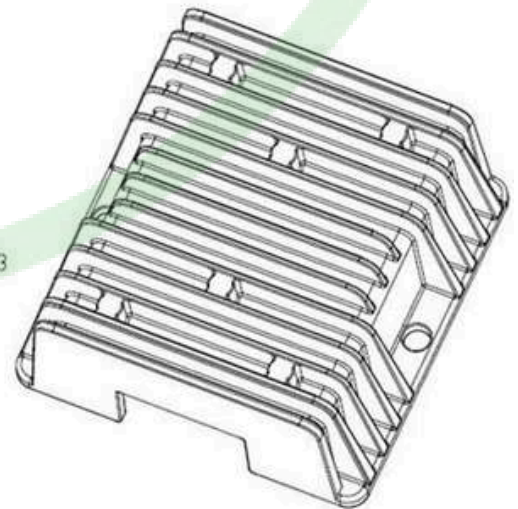
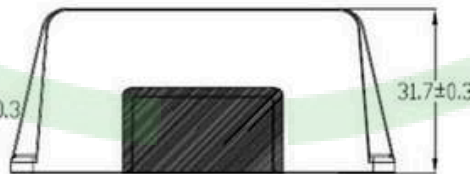
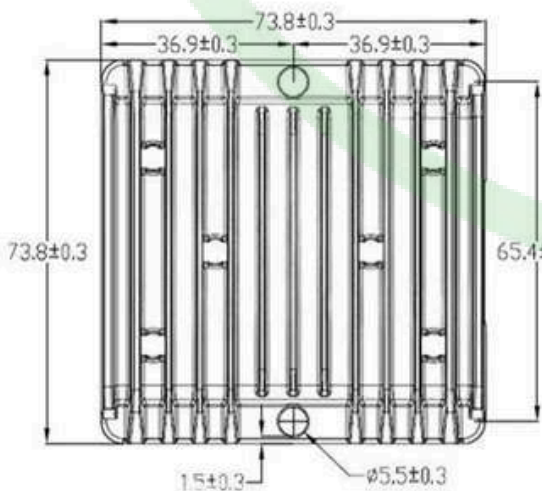
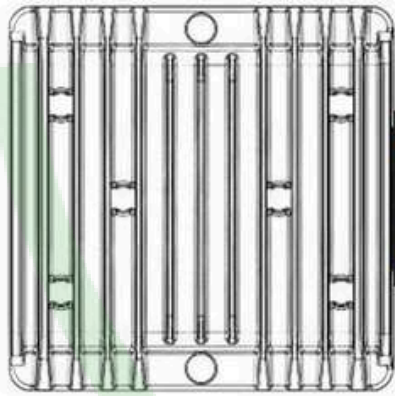
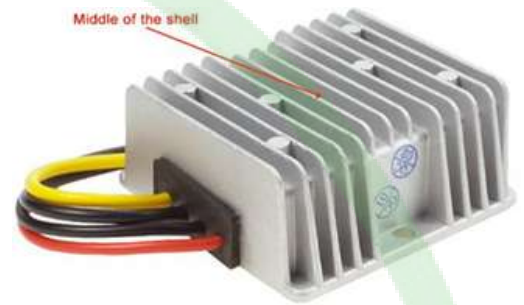

**NEWTECH ENTERPRISES Ltd reserves the ©copyright and right of final interpretation.**